

DIST.

A TERMINI DI LEGGE E' VIETATA LA RIPRODUZIONE O LA NOTIFICAZIONE DI QUESTO DISEGNO A TERZI SENZA AUTORIZZAZIONE

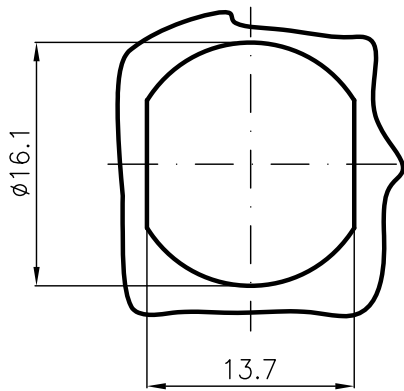
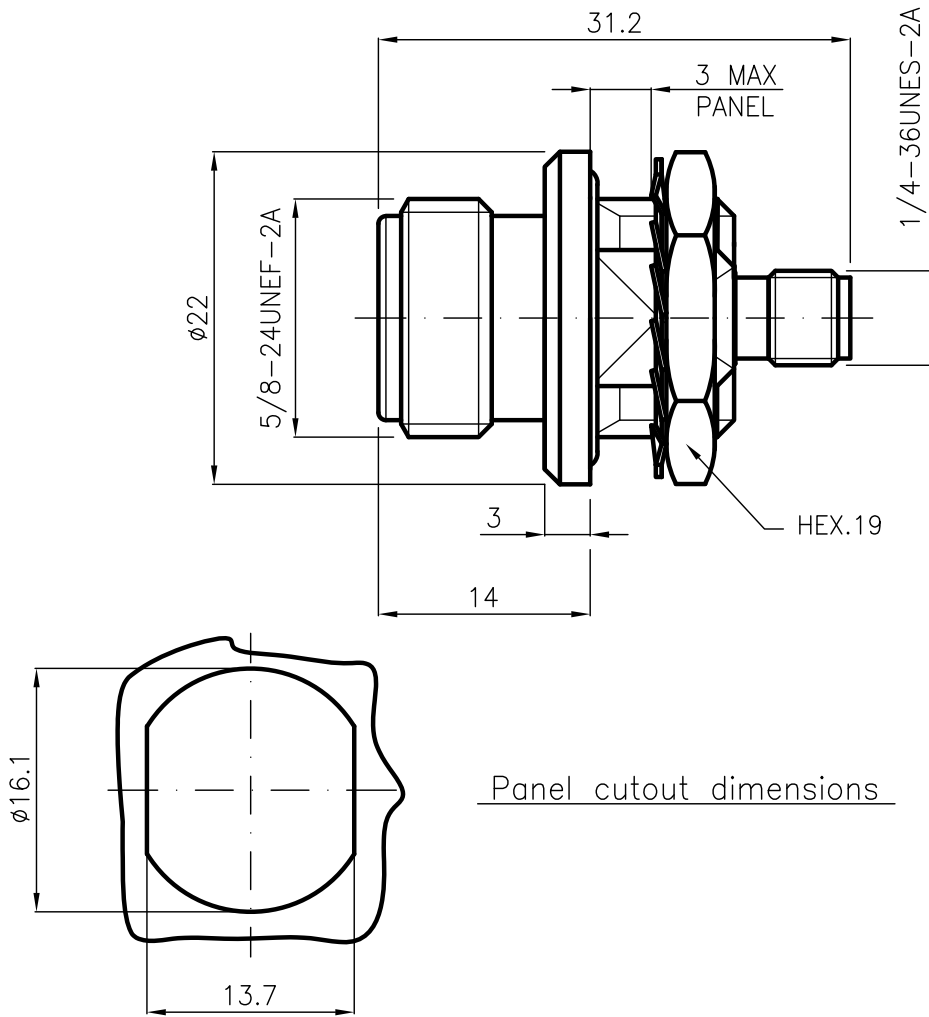

Panel cutout dimensions

SPECIFICATIONS

Mating and dimensions series N as per CECC 22210
 Mating and dimensions series SMA as per CECC 22110

ELECTRICAL

Frequency range	VSWR	
0 ÷ 1 GHz	≤ 1.02	(40 dB)
1 ÷ 3 GHz	≤ 1.04	(34 dB)
3 ÷ 6 GHz	≤ 1.12	(25 dB)
6 ÷ 8 GHz	≤ 1.22	(20 dB)
8 ÷ 12.4 GHz	≤ 1.50	(14 dB)

MATERIALS AND FINISH

Body N	Brass	White Bronze
Body SMA	Brass	Au
Center contact	Beryllium copper	Au
Insulator	PTFE	PTFE
Gasket	Silicon rubber	

DENOMINAZIONE

50 Ohm ADAPTER
 N SOCKET-SMA SOCKET-PANEL



01	LORENZON	30.06.10
/	EMESSO	26.03.04
REV.	N° MOD.	DATA

SCALA	2:1	CONTR. CUCCHI I.	DATA	26.03.04
FILE	NTR18002C-1	APPROV. CUCCHI M.	DIS.	Lorenzon I.

N° CODICE
NTR.18.002